

# RELIABLE FILTRATION

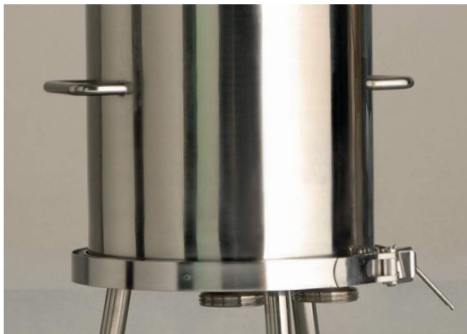

# ORBICOL MODULE FILTER

**HOBRA** ŠKOLNÍK

FILTER MEDIA  
FILTER EQUIPMENT AND TECHNOLOGY



# ORBICOL

ORBICOL module filters ( housings ) are characterized by high-quality workmanship and are made using only top-quality stainless steel of quality class AISI 316 L. The filters consist of a stand on three legs, a removable cover and attaching segment and are made in two basic versions, each in three volume sizes with a variety of optional output and input accessories.

The advantages of these devices include the fact that filtration is enclosed, airtight and leakage free, the filtration modules are simple and fast to handle and a relatively low volume of water is required for the regeneration, sanitation and sterilization of the modules. Another advantage is the vertical build of the device, which ensures high filtration power while needing the minimum of installation area. ORBICOL module filters are suitable for food&beverage, pharmaceutical, chemical and cosmetic industry, as well as for biotechnological applications and the filtration of industrial and vegetable oils. Thanks to the firm's many years of experience with liquid filtration, HOBRA can also offer specific solutions for the customer's entire filtration process.

The ideal medium for the ORBICOL filter are ORBIFILT filtration modules, which are available for all common applications.

## Available types and specifications of ORBICOL filters:

	unit	ORBICOL 30			ORBICOL 40		
		Size 1	Size 2	Size 3	Size 2	Size 3	Size 4
filtration area	m <sup>2</sup>	1.8	3.6	5.4	7.2	10.8	14.4
maximum operating pressure	bar	6	6	6	6	6	6
maximum operating temperature	°C	140	140	140	140	140	140
filter housing volume	l	25	50	75	105	148	192
unit weight (empty)	kg	40	60	80	70	90	110
unit weight (full)	kg	65	110	155	175	240	300

## Special variants of ORBICOL filters:

### ORBICOL 30 PTC

Orbicol 30 PTC is an industrial variant of the module filter. It is manufactured in two sizes. The ORBICOL 30 PTC has a bottom with three legs and a removable cover, which is attached by arc clamp screws or tensioners. An inlet and outlet are welded to the bottom. The cover contains a vent pipe with a manometer, sight glass and a sampling valve.

ORBICOL 30 PTC	unit	Size 1	Size 2
filtration area	m <sup>2</sup>	1.8	3.6
maximum operating pressure	bar	4	4
maximum operating temperature	°C	140	140
filter housing volume	l	27	50
unit weight (empty)	kg	40	60
unit weight (full)	kg	65	110

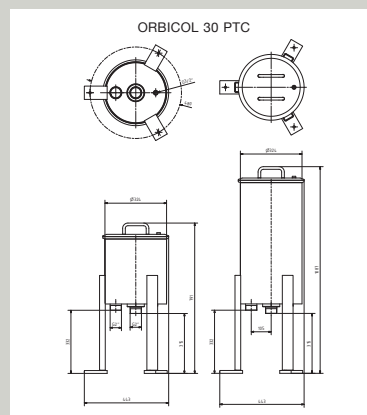

### ORBICOL 30 PTC oilset

The ORBICOL 30 PTC oilset is a modification of ORBICOL device that is installed on a movable chassis. The filter is intended for on-site filtration of hydraulic and mineral oils. The set also includes a fully-wired VISOMAT 70 sliding-vane pump to drive the filtered medium. The equipment also includes suction piping with a suction pipe and discharge piping at the end. The filter can be externally connected to a hydraulic tank for a limited period of time. It can also be used to fill hydraulic and other tanks with new oil.

ORBICOL 30 PTC oilset	unit	Size 1
filtration area	m <sup>2</sup>	1.8
maximum operating pressure	bar	4
maximum operating temperature	°C	60
filter housing volume	l	27
unit weight (empty)	kg	40
unit weight (full)	kg	65

